



Swing Check Valves Type Pressure Seal
Class 1500 DN 50-450 (2" – 18")
 Carbon, Alloy and Stainless Steel



Fig. VR1500PS

Design:
BS 1868 & API 6D / ISO 14313
ASME B16.34

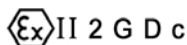



Swing Check Valves Class 1500

Type Pressure Seal

Parts and materials

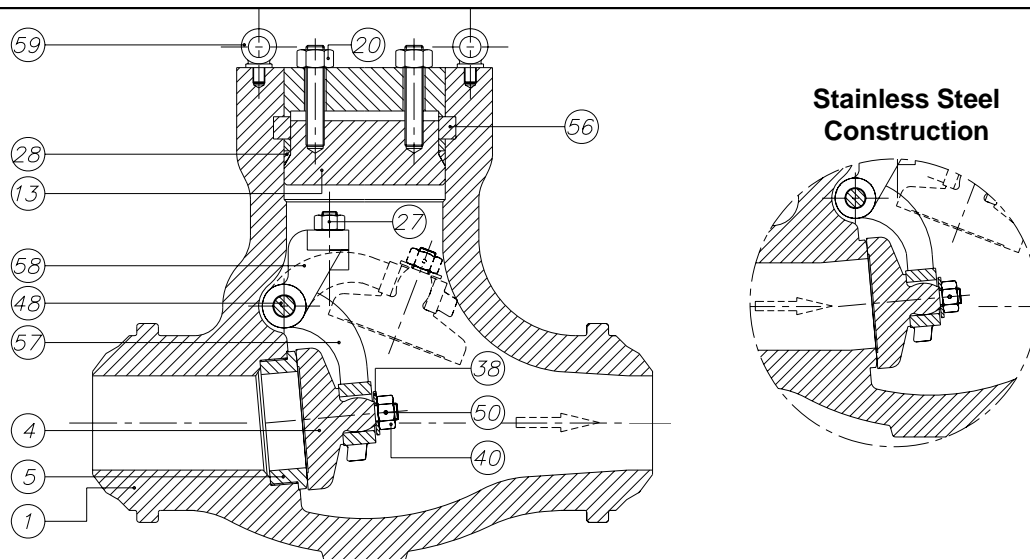

Trim Material

API 600 Trim No.	Stem / Backseat	Seating Surface Body / Wedge
1	13% Cr	13% Cr
2	SS 304	SS 304
3	SS310	SS310
4	13% Cr	13% Cr (Hard)
5 or 5A	13% Cr	HF
6	13% Cr	13% Cr / Cu Ni
7	13% Cr	13% Cr / 13% Cr (Hard)
8 or 8A	13% Cr	HF / 13% Cr
9	Monel	Monel
10	SS 316	SS 316
11 or 11A	Monel	HF / Monel
12 or 12A	SS 316	HF / SS 316
13	Alloy 20	Alloy 20
14 or 14A	Alloy 20	HF / Alloy 20

HF: Hard Facing using CoCr welding alloy (Stellite)

Item	Description	Material			
		Carbon Steel	Carbon Steel (Low Temp.)	Alloy Steel	Stainless Steel
1	Body	A 216 Gr.WCB	A 352 Gr.LCB	A 217 Gr.C5	A 351 Gr.CF8M
4	Disc	A 105 + Stellite	A 352 Gr.LCB + Stellite	A 182 Gr.F6a + Stellite	A 182 Gr.F316 + Stellite
5	Seat Ring	A 105 + Stellite	A182 Gr.F304 + Stellite	A 182 Gr.F6a + Stellite	A 182 Gr.F316 + Stellite
13	Cover	A 216 Gr.WCB / A 515 Gr.70	A 352 Gr.LCB	A 217 Gr.C5	A 351 Gr.CF8M
20	Cover Bolt & Nut	A 193 Gr.B7 / A 194 Gr.2H	A320 Gr. L7 / A194 Gr. 7	A 193 Gr.B7 / A 194 Gr.2H	A 193 Gr.B7 / A 194 Gr.2H
27	Bracket Stud & Nut	A 193 Gr.B8 / A 194 Gr.8	A 193 Gr.B8 / A 194 Gr.8	A 193 Gr.B8 / A 194 Gr.8	A 193 Gr.B8M / A 194 Gr.8M
28	Gasket	A182 Gr.F304	A182 Gr.F304	A182 Gr.F304	A182 Gr.F316
38	Washer	AISI 410	AISI 304	AISI 410	AISI 316
40	Disc Nut	AISI 304	AISI 304	AISI 304	AISI 316
48	Hinge Pin *	A182 Gr.F6a	A182 Gr.F304	A182 Gr.F6a	A 182 Gr.F316
50	Split Pin	AISI 304	AISI 304	AISI 304	AISI 316
56	Segmental Ring	A 105	A182 Gr.F304	A182 Gr.F6a	A182 Gr.F316
57	Hinge	A 216 Gr.WCB / A 515 Gr.70	A 352 Gr.LCB	A 217 Gr.C5	A 351 Gr.CF8M
58	Hinge Bracket	A 216 Gr.WCB / A 515 Gr.70	A 352 Gr.LCB	A 217 Gr.C5	A 351 Gr.CF8M
59	Lifting Hook	A105	A105	A105	A105

* It's also manufactured with Hinge Pin passing through body with plug



Swing Check Valves Class 1500

Type Pressure Seal

Dimensions

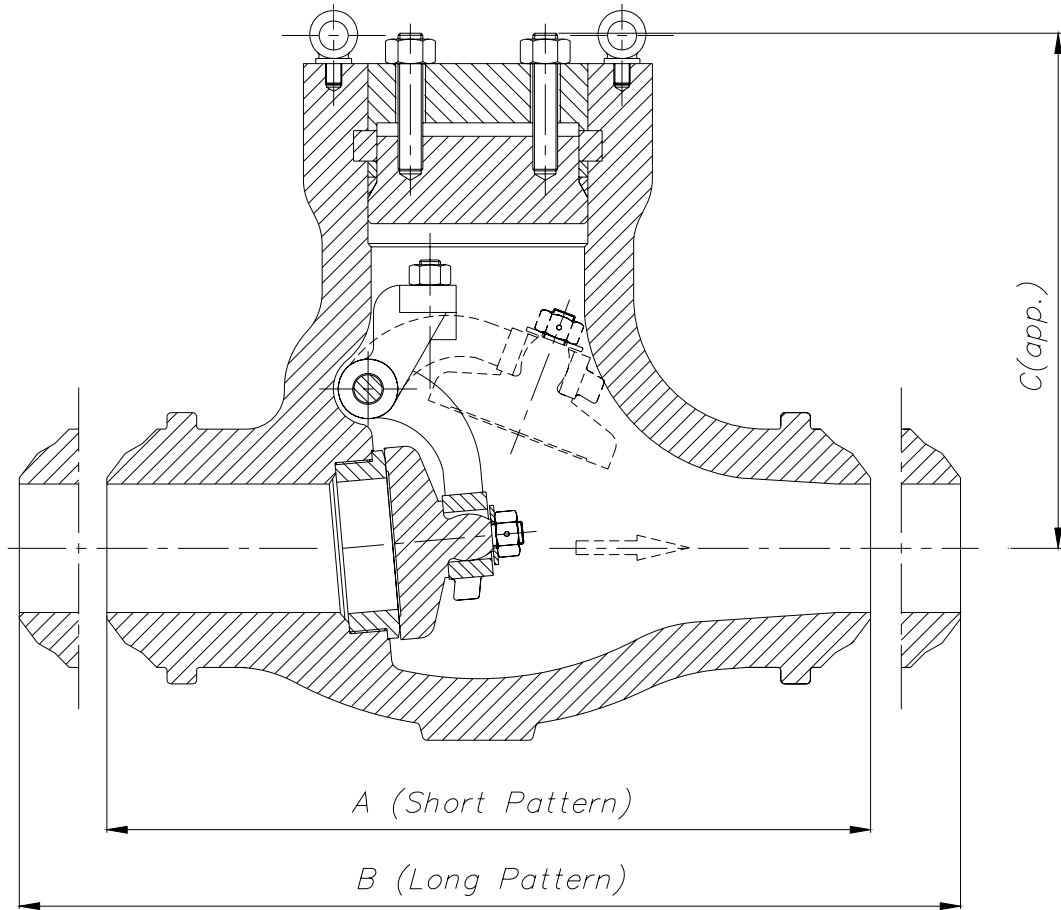

DN	A	B	C	WEIGHT
50 (2")	216	368	260	39
65 (2½")	254	419	285	63
80 (3")	305	470	300	87
100 (4")	406	546	370	130
125 (5")	483	673	415	197
150 (6")	559	705	450	316
200 (8")	711	832	615	540
250 (10")	864	991	660	1050
300 (12")	991	1130	750	1780
350 (14")	1067	1257	850	2320
400 (16")	1194	1384	960	2650
450 (18")	1537	1537	1070	2985

(*) Dimensions in mm and weight in kg.



Swing Check Valves Class 1500

Type Pressure Seal

General Characteristics, Cv, P&T Rating

GENERAL CHARACTERISTICS		Fig. VR1500PS			
DESIGN STANDARDS					
Valves design	BS 1868 & API 6D	ASME B16.34			
End to End Dimensions	ASME B16.10 & ISO 5752				
Flanged Dimensions	ASME B16.5 & ISO 7005-1 Part. 1	ASME B16.47	BS 3293	MSS SP-44	
Buttweld Dimensions	ASME B16.25				
Visual Inspection	MSS SP- 55				
Marking	MSS SP-25 & ISO 5209				
TESTS AND CERTIFICATES					
Pressure testing	API 598 & ISO 5208	BS 6755 Part. 1	MSS SP-61		
Other	ATEX, CE				

Cv Values in U.S. Gallons/min.

DN	Cv	DN	Cv
50 (2")	100	200 (8")	1200
65 (2½")	160	250 (10")	1900
80 (3")	220	300 (12")	2300
100 (4")	400	350 (14")	3500
125 (5")	610	400 (16")	4700
150 (6")	800	450 (18")	5400

Pressure-Temperature (STANDARD CLASS According to ASME B16.34)

Temp °C	MATERIAL			
	A216 WCB Bar	A352 LCB Bar	A217 C5 Bar	A351 CF8M (**) Bar
-29 to 38	255,3	239,1	258,4	248,0
95	232,5	226,0	256,7	213,2
150	226,0	219,8	246,7	192,6
205	218,4	212,6	243,2	177,1
260	206,4	200,5	229,1	164,7
315	188,4	183,6	208,4	155,4
345	185,0	180,2	202,6	153,0
375	183,6		195,7	149,5
400	173,6		181,9	147,1
425	141,9		175,0	145,4
450	92,3		166,4	144,0
485	59,3		127,5	143,0
510	35,5		94,4	133,0
540	17,9		68,6	120,6
565			49,6 *	118,5 *
595			34,1 *	105,1 *
620			21,4 *	81,6 *
650			11,7 *	63,7 *
675				50,6 *
705				40,3 *
735				33,1 *
760				26,2 *
790				20,0 *
815				14,1 *

* FOR WELD END VALVES ONLY. FLANGED END RATINGS TERMINATE AT 540°C

** A351 CF8M at temperatures over 538°C (1000°F) to be used only if Carbon contents is 0,04% or higher.